

A Molecular Clip That Binds Aromatic Guests by an Induced-Fit Mechanism

R. P. Sijbesma,[†] Sybren S. Wijmenga,[†] and R. J. M. Nolte*[†]

Contribution from the Department of Organic Chemistry and the National HF-NMR Facility, NSR Center, University of Nijmegen, Toernooiveld, 6525 ED Nijmegen, The Netherlands.

Received May 1, 1992

Abstract: The conformational behavior and binding properties of a novel molecular receptor consisting of a diphenylglycoluril unit flanked by two 2,7-disubstituted naphthalene rings is described. The molecule appears in three conformations. These conformations differ in the way that the naphthalene rings are oriented with respect to the two phenyl groups on the concave side of the glycoluril moiety, viz. anti-anti, syn-anti, and syn-syn. The receptor is able to change from one conformation to another by flipping the naphthalene walls. The mechanism and the rate constants for this process were determined by 2D EXSY NMR techniques. One of the three conformations contains a cavity, within which aromatic guest molecules of appropriate size can be bound selectively.

Introduction

One of the major themes in host-guest chemistry is the exploration of the potentialities of different kinds of intermolecular interactions in the rational design of new host compounds. Most hosts developed in the last decades are crown ether compounds, which bind the guest by strong ion-dipole interactions. The use of weak forces between neutral molecules, such as hydrogen bonding and π - π stacking, has attracted attention only much more recently.

Several research groups, including those of Rebek,¹ Whitlock,² Zimmerman,³ and Hamilton,⁴ have shown that it is feasible to bind guests by a combination of π - π interactions and hydrogen bonding. Binding of neutral guests by π - π interactions alone has also been achieved: Diederich⁵ has synthesized cyclophanes that bind aromatic guests not only in water, where the hydrophobic effect has a stabilizing influence, but also in organic solvents. The interactions between the guest and the aromatic moieties of his hosts are of the edge-to-face type. Stoddart⁶ has used hosts with positively charged aromatic moieties to bind dimethoxybenzenes. Recently, Zimmerman⁷ has synthesized so-called "molecular tweezers", which bind tetranitrofluorenone between two parallel acridine surfaces. Harmata⁸ has published a report of a crystal structure of a compound which sandwiches a molecule of trinitrobenzene between two dibenzofuran surfaces, but the complexing behavior in solution was not discussed. Lehn⁹ has developed a host with two naphthalene units that sandwich a nitrobenzene guest in the solid state.

We have used glycoluril as a building block for developing receptors of type 1, which bind dihydroxy-substituted aromatic guests by means of hydrogen bonding as well as π - π interactions.¹⁰ We were, however, also interested in binding neutral molecules

in 1 by π - π interactions alone. To achieve this, we increased the size of the aromatic pocket of the original receptor by using 1,4-dimethoxynaphthalene walls (see compound 2).¹¹ However, in molecule 2 the methoxy groups were found to block the cavity of the receptor, thus preventing the complexation of a guest. An attempt to prepare the analog of receptor 2 without methoxy groups from a glycoluril derivative and naphthalene yielded an unseparable mixture of host compounds with the naphthalene walls attached to the glycoluril unit at the 1,2- and 1,8-positions.¹² We therefore set out to prepare a receptor with 2,7-dimethoxynaphthalene walls, see 3.

Results and Discussion

Synthesis. Starting compound 4¹² was refluxed in 1,2-dichloroethane with 2,7-dihydroxynaphthalene and SnCl₄ as a catalyst to give 3b (64% yield). Compound 3b was acetylated in acetic anhydride to yield 2c in 41%. Compound 3d was prepared in 76% yield by alkylation of 3b with dimethyl sulfate in DMSO, using powdered KOH as a base.

NMR Spectra and Conformations. The ¹H NMR spectrum of the reaction mixture from which 3b is isolated is much more complicated than would be expected for a single product. This complexity could arise if the product is a mixture of isomers, having different substitution patterns at the naphthalene moieties, or if 3b exists as a mixture of conformational isomers that in-

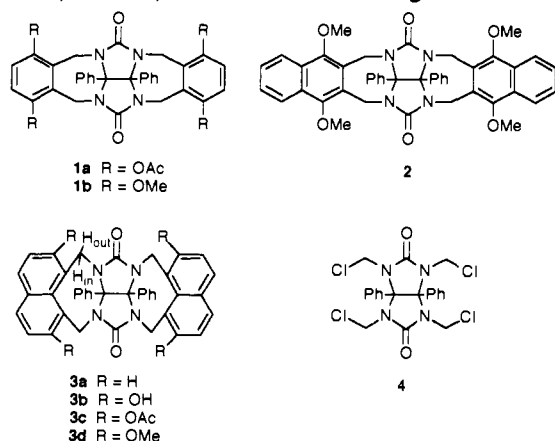

[†]Department of Organic Chemistry.

[‡]National HF-NMR Facility.

- (1) Rebek, R., Jr. *Angew. Chem.* **1990**, *102*, 261.
- (2) (a) Sheridan, R. E.; Whitlock, H. W., Jr. *J. Am. Chem. Soc.* **1986**, *108*, 7120. (b) Whitlock, B. J.; Whitlock, H. W., Jr. *J. Am. Chem. Soc.* **1990**, *112*, 3910. (c) Neder, K. M.; Whitlock, H. W. *J. Am. Chem. Soc.* **1990**, *112*, 9412. (d) Cochran, J. E.; Parrot, T. J.; Whitlock, B. J.; Whitlock, H. W., Jr. *J. Am. Chem. Soc.* **1992**, *114*, 2269.
- (3) (a) Zimmerman, S. C.; Zeng, Z.; Wu, W.; Reichert, D. E. *J. Am. Chem. Soc.* **1991**, *113*, 183. (b) Zimmerman, S. C.; Wu, W.; Zeng, Z. *J. Am. Chem. Soc.* **1991**, *113*, 196.
- (4) Goswami, S.; Hamilton, A. D.; van Engen, D. J. *J. Am. Chem. Soc.* **1989**, *111*, 3425.
- (5) (a) Diederich, F.; Ferguson, S. B. *Angew. Chem.* **1986**, *98*, 1127. (b) Ferguson, S. B.; Sanford, E. M.; Seward, E. M.; Diederich, F. *J. Am. Chem. Soc.* **1991**, *113*, 5410. (c) Smithrud, D. B.; Wyman, T. B.; Diederich, F. *J. Am. Chem. Soc.* **1991**, *113*, 5420.
- (6) Ashton, P. R.; Odell, B.; Reddington, M. V.; Slawin, M. Z.; Stoddart, J. F.; Williams, D. J. *Angew. Chem.* **1988**, *100*, 1608.
- (7) (a) Zimmerman, S. C.; van Zyl, C. M. *J. Am. Chem. Soc.* **1987**, *109*, 7894. (b) Zimmerman, S. C.; Wu, W. *J. Am. Chem. Soc.* **1989**, *111*, 8054. (c) Zimmerman, S. C.; van Zyl, C. M.; Hamilton, G. S. *J. Am. Chem. Soc.* **1989**, *111*, 1373.
- (8) Harmata, M.; Barnes, C. L. *J. Am. Chem. Soc.* **1990**, *112*, 5655.
- (9) Jazwinski, J.; Blacker, A. J.; Lehn, J.-M.; Cesario, M.; Guilhem, J.; Pascard, C. *Tetrahedron Lett.* **1987**, 6057.
- (10) (a) Sijbesma, R. P.; Nolte, R. J. M. *J. Org. Chem.* **1991**, *56*, 3122. (b) Sijbesma, R. P.; Kentgens, A. M.; Nolte, R. J. M. *J. Org. Chem.* **1991**, *56*, 3199.
- (11) Sijbesma, R. P.; Bosman, W. P.; Nolte, R. J. M. *J. Chem. Soc., Chem. Commun.* **1991**, 885.
- (12) Sijbesma, R. P.; Nolte, R. J. M., submitted for publication.

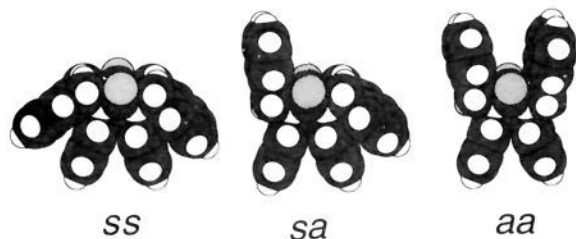

Figure 1. Calculated structures of the three conformers of **3a**.

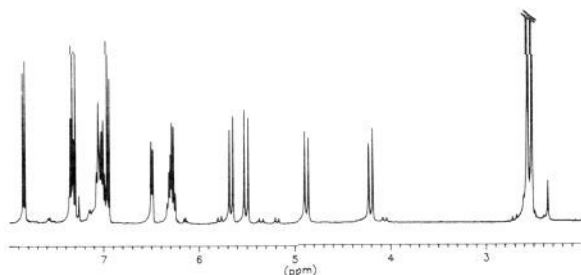

Figure 2. 400-MHz ^1H NMR spectrum of **3c**.

terconvert slowly on the NMR timescale. As **3b** is only soluble in DMSO, it could not be subjected to column chromatography. The tetraacetyl derivative **3c**, however, is soluble in CHCl_3 and eluted as a single product, suggesting that only one diastereomer was present. Upon heating a sample of **3c** above room temperature, the peaks in the 90-MHz spectrum broadened, and above 353 K, several resonances coalesced, resulting in a much simpler spectrum. Our tentative conclusion was that **3** is present as a mixture of conformers that interconvert slowly on the NMR timescale at room temperature. This hypothesis could be confirmed by extensive 400-MHz NMR studies on **3c** and **3d**, as will be described below.

The naphthalene moieties in **3** can have two orientations, allowing for the existence of three conformers of **3**: anti-anti (aa), syn-anti (sa), and syn-syn (ss) (see calculated structures of **3a**, Figure 1).

The ^1H NMR signals of these conformers can be found in three regions: the aromatic region, with the signals of the phenyl and naphthyl groups; the CH_2 region, with an AB pattern for each distinct CH_2 group; and the region with the signals of the methoxy or acetoxy groups.

The CH_2 region of the 400-MHz ^1H NMR spectrum of **3c** in CDCl_3 at 298 K (4–6 ppm, Figure 2) has four doublets with $J = 15.3$ Hz and four doublets with $J = 16.4$ Hz. This is the number of signals that can be expected if all conformers are present in solution, viz. one AB quartet for each of the ss and aa conformers and two AB quartets for the less-symmetrical sa conformer. Figure 2 shows four doublets of high and equal intensity and four of low intensity. In $\text{DMSO}-d_6$, two of the lower-intensity doublets are significantly smaller than the other two. The four high-intensity doublets must therefore be assigned to the sa conformer, since for this conformer these signals are necessarily of equal intensity.

The assignment of the low-intensity doublets to the aa and ss conformers of **3c** was performed with the aid of calculations of the ring current contributions to the shifts of the CH_2 signals in these conformers. The ring current contributions were calculated with the aid of the Johnson–Bovey tables¹³ and the atomic coordinates of the modeled structures of the three conformers of **3**. The ring current shift contribution of a naphthalene group was assumed to be the same as the contribution of two benzene rings at the positions of the two six-membered rings in naphthalene. To obtain suitable reference shifts for the in and out protons of **3c** (see structural formula of **3**), the calculated ring current contributions to the shift of the in and out CH_2 protons of **1a** were

Table I. Assignments of Resonances to the Conformations of **3c** and **3d**^a

	3c			3d		
	aa	ss	sa	aa	ss	sa
NCH ₂ out ^b	5.33	5.76	5.65 (s)	5.88	6.23	6.05 (s)
			5.49 (a)			5.97 (a)
NCH ₂ in ^b	4.05	5.16	4.87 (s)	3.97	5.13	4.81 (s)
			4.19 (a)			4.14 (a)
OMe/OAc	<i>c</i>	<i>c</i>	2.55	4.13	3.97	4.15
			2.51			3.92
naphthalene-H ³	<i>c</i>	<i>c</i>	7.34 (a)	<i>c</i>	<i>c</i>	7.20 (a)
			6.94 (s)			6.84 (s)
naphthalene-H ⁴	<i>c</i>	<i>c</i>	7.84 (a)	<i>c</i>	<i>c</i>	7.75 (a)
			7.30 (s)			7.23 (s)
phenyl-H ^{2,6}	<i>c</i>	<i>c</i>	6.49 (s)	<i>c</i>	6.33	6.51 (s)
			7.0 (a)			
phenyl-H ^{3,5}	<i>c</i>	<i>c</i>	6.26 (s)	<i>c</i>	6.00	6.13 (s)
			7.05 (a)			
phenyl-H ⁴	<i>c</i>	<i>c</i>	6.30 (s)	<i>c</i>	~6.15	6.24 (s)
			7.05 (a)			

^aShifts are in ppm. The designations (s) and (a) are used for the CH_2 protons on the side of the molecule where the naphthyl groups have a syn or anti orientation relative to the phenyl groups, respectively (see Figure 1). ^bThe designations in and out are used as indicated in the structural formula of **3**. ^cDue to the low abundance of the conformer, no assignment could be made.

subtracted from the measured shifts in **1a**. The shifts in the aa conformer of **3c** were obtained by adding the calculated ring current shifts to these reference shifts. The same was done for the ss conformer of **3c**. The calculated shifts are 5.25 and 3.95 ppm ($\Delta\delta = 1.30$ ppm) in the aa conformer and 5.40 and 4.59 ppm ($\Delta\delta = 0.81$ ppm) in the ss conformer. These results coincide reasonably well with the experimental values: 5.33 and 4.05 ($\Delta\delta = 1.28$ ppm) and 5.76 and 5.16 ppm ($\Delta\delta = 0.60$ ppm). On these grounds, the former AB quartet was assigned to the aa conformer. In the same manner, the AB quartets of **3d** were assigned from the spectrum of **1b** in combination with ring current calculations.

The aromatic region of the spectrum of **3c** (6–8 ppm) is also complicated (Figure 2). It is to be expected that in the syn orientation, the signals of the naphthyl and phenyl groups undergo considerable upfield shifts, due to the ring current effect of these moieties. For the naphthyl groups of the sa conformer of **3c**, two AB quartets are found at 7.84 and 7.34 ppm and at 7.30 and 6.94 ppm, respectively. The fact that the signals of the naphthyl groups are present as AB quartets is strong evidence that these moieties are, indeed, attached to the diphenylglycoluril framework at the 1 and 8 positions.

The signals of the phenyl group on the syn side of the sa conformer of **3c** have shifted 0.5–0.8 ppm upfield relative to the signals on the anti side. In **3d**, some of the aromatic signals and the methoxy signals of the less abundant conformers could be assigned with the help of COSY spectra and from the spectra of the complexes of this compound.

After we assigned the resonances (see Table I), the relative abundances of the different conformers could be determined by integration of the spectra. In CDCl_3 solution at 298 K, 91% of the molecules of **3c** are in the sa conformation, 4.7% in the ss conformation, and 4.3% in the aa conformation. For **3d**, these values are 89.6%, 7.7%, and 2.7%, respectively.

It is of interest to ask why the asymmetric sa conformer is present in such high concentrations. The naphthyl moieties in **3** are separated by a rigid glycoluril unit, which has more or less the same conformation in all three conformers. One would therefore expect that the lowest-energy orientation of the naphthyl group is either syn or anti. A distortion in the glycoluril unit preserving a 2-fold rotational symmetry in the glycoluril unit will not change this. We believe that the stability of the conformers of **3** is governed by solvation. The distance between the naphthyl groups in the aa conformer of **3** is only ~ 6 Å. This distance is too small for solvent molecules to solvate the inner surfaces of the cavity in this molecule. A higher energy of the syn orientation in the sa conformer of the unsolvated molecule could be com-

(13) Johnson, C. S., Jr.; Bovey, F. A. *J. Chem. Phys.* 1958, 29, 1012.

compensated for in solution by a better solvation of the naphthyl surfaces. When the sa conformer converts into the ss conformer, no such compensation will be available. In other words, the sa conformer is preferred because it has the highest number of naphthyl surfaces exposed to the solvent.

Molecular Mechanics Calculations. The relative energies of the three conformers of **3a** were determined with the help of molecular mechanics calculations. In these calculations, three different force fields were used: MM2P(85),¹⁴ MMX,¹⁵ and the force field developed by Warshel.¹⁶ MMX offers the capabilities for calculating electrostatic energies either with atomic point charges or with bond dipoles. Both options were used. Three local energy minima, corresponding to the aa, sa, and ss conformations, were found with all force fields. The conformations calculated with the different force fields had very similar geometries. In Figure 1, the geometries that were obtained with the MM2P(85) force field are shown.

Kinetics of Conformational Equilibria. Our variable temperature ¹H NMR experiments showed that the three conformers of **3** interconvert in solution. In simple systems with few exchanging sites, it is possible to extract rate constants by band shape analysis of the spectra.¹⁷ However, with the complexity encountered here, 2D-exchange spectroscopy (EXSY) is a superior method for elucidating exchange pathways and for determining rate constants.¹⁸ In the EXSY experiment, a pulse sequence is used which was originally proposed by Jeener.¹⁹ Sites that exchange population during the mixing time (τ_m) give rise to crosspeaks. Direct processes can be distinguished from indirect ones by recording spectra at different mixing times, monitoring the crosspeak intensity as a function of τ_m . Crosspeaks arising from indirect processes have a zero time derivative at very short mixing times, whereas crosspeaks from direct processes have a nonzero time derivative. The initial slope of the crosspeak intensity is a direct measure of the rate constant. In principle, one 2D EXSY spectrum at an appropriate value of τ_m would suffice for determining all rate constants, but in practice, without previous knowledge of rate constants,²⁰ spectra at a number of different mixing times should be recorded.

In the present case, it is not possible to distinguish direct from indirect processes by taking spectra at very short mixing times. Because of the large difference in population of the three conformers, the crosspeaks between the signals of the most abundant sa conformer will be the strongest for all but the shortest mixing times, even if the corresponding direct process has a zero rate constant. Even if qualitative information is to be extracted, spectra with very short mixing times will have to be recorded. This, however, is precluded again by the large population differences in **3**, since at these short mixing times very small crosspeaks would have to be detected in the presence of (and in some cases near to) very large peaks on the diagonal.

The inability to obtain the necessary information from first-order crosspeaks at small mixing times forced us to determine rate constants from an analysis of crosspeak intensities at longer mixing times. Perrin^{20a} and Abel et al.^{20b} have developed a method, based on a matrix formalism, for evaluating rate constants from non-first-order crosspeaks. With this method, it is in principle possible

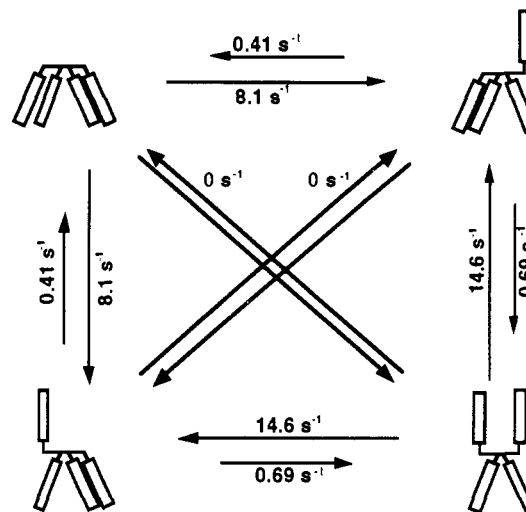

Figure 3. Scheme of conformational exchange processes and their rate constants in **3c**.

Table II. Apparent Rate Constants (s^{-1}) of the Exchange Processes in **3c**^a

	1	2	3	4
1		3.98 ± 0.28	4.14 ± 0.47	0
2	0.402 ± 0.025		0	0.678 ± 0.047
3	0.418 ± 0.045	0		0.937 ± 0.084 (0.71) ^b
4	0	7.16 ± 0.50	9.93 ± 0.87 (7.48) ^b	

^aNumbering of sites corresponds to that in Chart I. ^bAfter correction for peak overlap (see text).

to determine rate constants from a single EXSY spectrum. As the accuracy of the method is dependent on the choice of the appropriate mixing time and as we had no previous knowledge of the exchange rates in our system, we chose to take spectra at a number of mixing times. This has the additional advantage that the reproducibility of the results of the individual experiments gives a good estimate of the accuracy of the rate constants.

For the successful elucidation of exchange pathways, a number of conditions must be fulfilled. The compound should have non-overlapping resonances for each of the conformers, and each conformer should have a population that is large enough to give peaks with sufficient signal-to-noise ratios. For these reasons, we used solutions of **3c** in $CDCl_3$ in our EXSY experiments. The CH_2 region in the spectrum of this compound has free-lying peaks of sufficient intensity for all conformers. On the contrary, in the spectrum of **3d**, the peaks of the aa conformer have a marginal signal-to-noise ratio due to the low abundance (2.7%) of this conformer.

Two different types of exchange processes between the three conformers of **3** can be envisioned. By changing the orientation of one naphthyl group from syn to anti or vice versa, population exchange between the aa and sa conformers, as well as between the ss and sa conformers, occurs. These processes are represented by the vertical and horizontal arrows in Figure 3. When two naphthyl groups flip simultaneously, the ss and aa conformers are interconverted directly, and, by such a simultaneous flip, the sa conformer is converted into itself. This degenerate process can be monitored by virtue of the magnetic inequivalence of the sites on the syn and anti part of the molecule. The double-flip processes are represented by the diagonal arrows in Figure 3.

The CH_2 region (4–6 ppm) of the EXSY spectrum of **3c**, recorded at a mixing time of 100 ms, is presented in Figure 4.

For each of the single-flip processes, there are four crosspeaks, two from the CH_2 protons on the side that changes conformation and two from the CH_2 protons on the side that retains its conformation. For each of the double-flip processes, the EXSY spectrum has two crosspeaks. This redundancy offers an additional opportunity to check the accuracy of the experimental results.

(14) MM2P(85) is an improved and enlarged version of MM2P; see: Sprague, J. T.; Tai, J. C.; Yuh, Y.; Allinger, N. L. *J. Comput. Chem.* **1987**, *8*, 581 and references cited therein.

(15) MMX88 (QCPE 395).

(16) Warshel, A. In *Modern Theoretical Chemistry*; Segal, G., Ed.; Plenum: New York, 1977; Vol. 7.

(17) Sandstrom, J. *Dynamic NMR Spectroscopy*; Academic Press: London, 1982.

(18) (a) Ernst, R.; Bodenhausen, G.; Wokaun, A. In *Principles of Nuclear Magnetic Resonance in One and Two Dimensions*; International Series of Monographs on Chemistry; Breslow, R., Halpern, J., Rowlinson, J. S., Eds.; Oxford University Press: New York, 1987; Vol. 14. (b) For a review of this method, see: Perrin, C. L.; Dwyer, T. *Chem. Rev.* **1990**, *90*, 935.

(19) Jeener, J.; Meier, B. H.; Bachmann, P.; Ernst, R. R. *J. Chem. Phys.* **1979**, *79*, 4546.

(20) (a) Perrin, C. L.; Gipe, R. K. *J. Am. Chem. Soc.* **1984**, *106*, 4036. (b) Abel, E. A.; Coston, T. P. J.; Orrell, K. G.; Sik, V.; Stephenson, D. J. *Magn. Reson.* **1986**, *70*, 34.

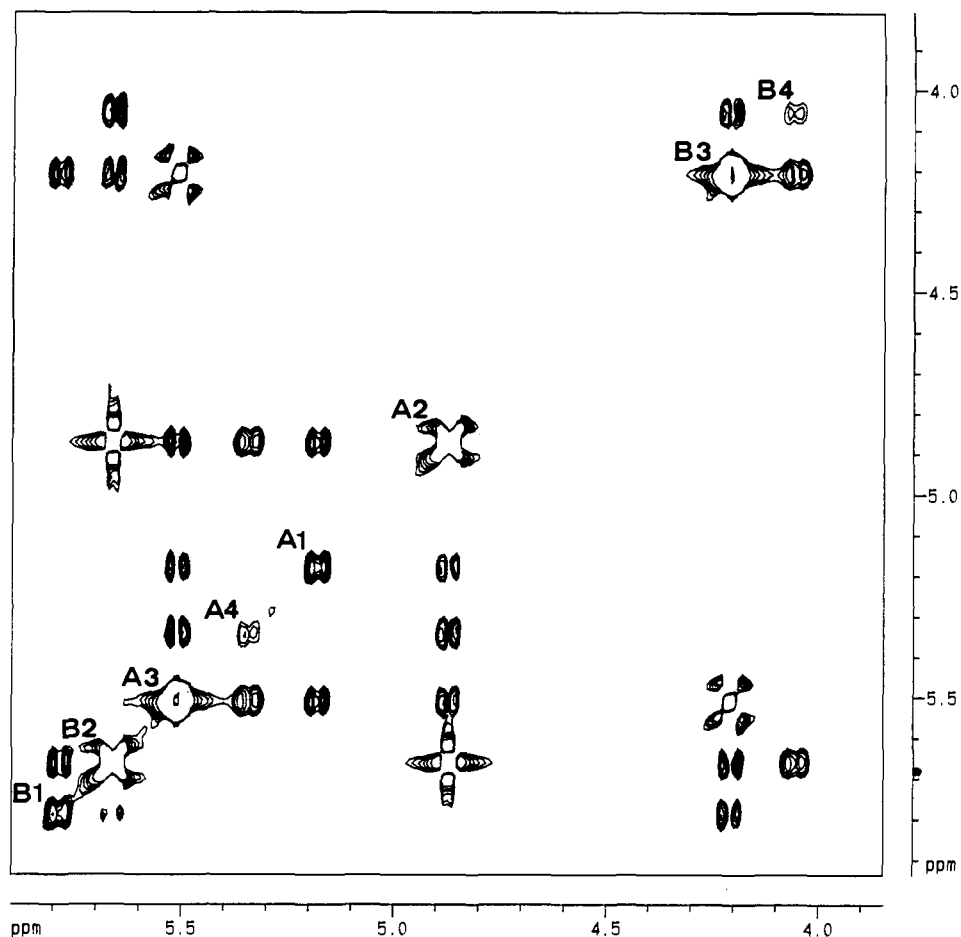
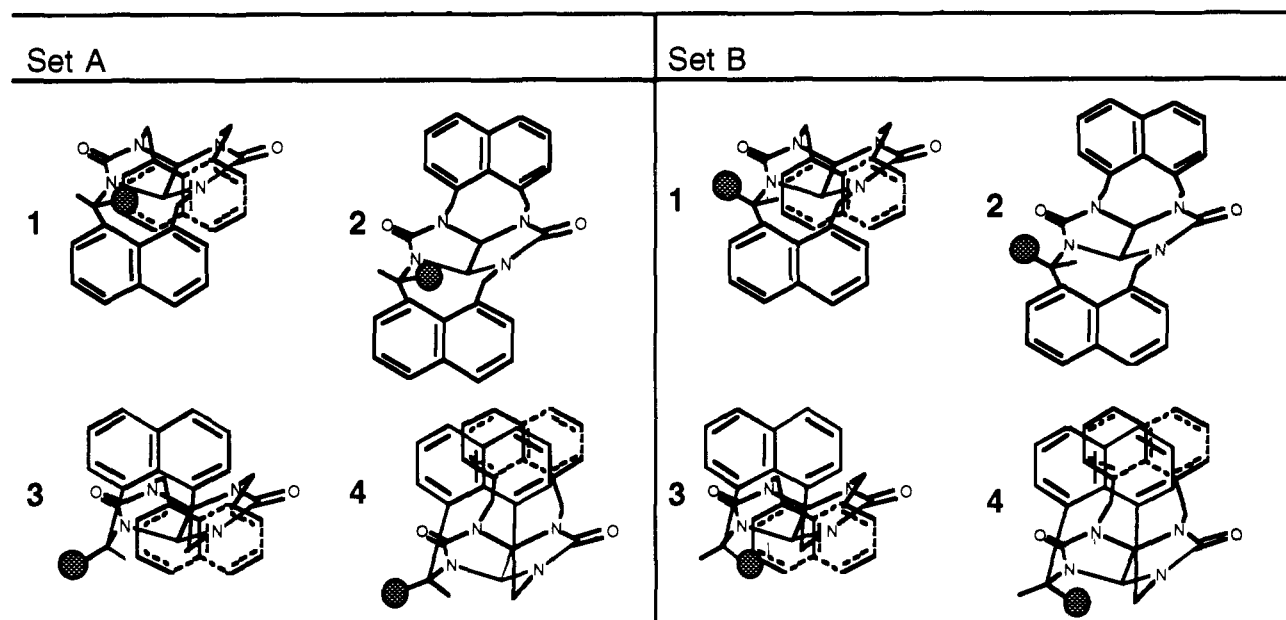

Figure 4. Contour plot of the CH₂ region of the EXSY spectrum of **3c** ($\tau_m = 100$ ms, $T = 308$ K). The crosspeaks with dispersive line shape are due to zero quantum coherence between coupled signals. The assignments correspond to the numbering of the sites in Chart I.

Chart I. Two Separate Sets of CH₂ Sites in **3c**^a



^aThe phenyl groups and the substituents on the naphthyl groups have been omitted for clarity.

The eight doublets in the CH₂ region consist of two separate sets of four resonances, corresponding to two sets of magnetic sites. Sites in one set do not exchange with sites in the other set. Of these two sets (Chart I), only the resonances belonging to the sites in set A have been used, since in set B some of the crosspeaks were very close to the diagonal, resulting in severe interference of these

small peaks by intense peaks on the diagonal.

EXSY spectra were recorded at mixing times of 10, 20, 30, 50, 75, and 100 ms. Volumes of the diagonal peaks and crosspeaks of the signals of subset A were determined, and from these intensity matrices and the population matrix the various apparent rate constants were calculated. Their average values and standard

Table III. Rate Constants (s^{-1}) of Exchange Processes in **3c** and Ratio of Rate Constants Compared to the Ratio of Populations of Conformers of **3c**

process	rate constant	inverse process	rate constant	ratio of rate constants	ratio of populations ^a
$k_{(aa \rightarrow sa)}$	0.69	$k_{(sa \rightarrow aa)}$	14.6	21.2	21.4
$k_{(sa \rightarrow ss)}$	0.41	$k_{(ss \rightarrow sa)}$	8.1	19.8	19.4
$k_{(aa \rightarrow ss)}$	0				
$k_{(ss \rightarrow aa)}$	0				

^a Determined from the intensity of the diagonal peaks in a spectrum with zero mixing time.

deviations are given in Table II.

The reliability of the data in Table II can be checked in a number of ways. First, one may consider the standard deviations, which indicate that excellent agreement exists between the results obtained from experiments at different mixing times. Standard deviations are in the range of 6–11%. Moreover, the rate constants derived at individual mixing times varied randomly when the mixing time was increased, suggesting that there are no τ_m -dependent systematic errors in the data.

Second, because in the EXSY experiment the rate constants of the single-flip processes are determined twice, the values for identical processes should be equal. For the exchange process *ss*–*sa* (between sites 1 and 2 and between 1 and 3), this is, indeed, the case. The values are the same within experimental error. For the *aa*–*sa* process (between sites 4 and 2 and between 4 and 3), the rate constants for exchange between site 4 and 3 are significantly higher than the other ones. Because the crosspeaks from which the higher rate constants were determined suffered most from overlap with a diagonal peak (they are only at 0.16-ppm distance from a diagonal peak with 117 times the intensity of these crosspeaks) we felt it was necessary to apply the following correction to the intensity matrix: for each crosspeak, a straight line was fitted through the first three points of the crosspeak intensity vs the mixing time curve. The intercepts of these lines at zero mixing time were subtracted from the crosspeak intensities at 50- and 100-ms mixing time. The average kinetic matrix calculated from these corrected intensity matrices was identical to the uncorrected matrix within experimental error, except for the two rate constants derived from the crosspeaks close to the diagonal. After correction, these rate constants became identical with the other rate constants calculated for the same processes.

A third check on the reliability of the results is in the fact that the ratio of forward and backward rate constants should be identical to the ratio of the populations of the sites. The ratio of rate constants does show good agreement with the ratio of populations calculated from the diagonal peak intensities at zero mixing time (Table III). It should be noted that there are two ways to convert the *ss* and the *aa* conformer into the *sa* conformer but only one way to convert the *sa* conformer into an *aa* conformer or into an *ss* conformer. The rate constants for *aa* \rightarrow *sa* and *ss* \rightarrow *sa* processes, therefore, have to be multiplied by two in order to obtain the correct rate constants.

As the results are internally consistent, we may feel confident that the rate constants are as given in Table III. The most significant conclusion is that the double-flip processes have zero rate constants. The single-flip processes have different rate constants, which does not, however, lead to different populations of the *aa* and *sa* conformers.

Complexation Studies. The *aa* conformer of **3** has a geometry that is quite well-suited to host a guest. In the modeled structure of this conformer, the naphthalene moieties are at a relative angle of 22°. The aromatic carbon atoms at the rim of the cavity are approximately 6.5 Å apart. This is the optimal distance for sandwiching an aromatic guest. Due to the electron-donating properties of the dimethoxynaphthalene moieties in **3d**, guests with electron-acceptor groups are the most suitable candidates for strong binding.

We studied the complexation of 12 guests by **3d** with the help of ¹H NMR and UV. We found that when a guest is bound to **3d**, the relative amount of the *aa* conformer increases and its

Table IV. Apparent K_a Values of the *aa* Conformation of **3d** and of Hexamethylbenzene with Aromatic Guests in CDCl₃ at 298 K

guest	K_a 3d ^a	$\frac{[sa]}{[ss]}$	K_a (hexamethylbenzene)
toluene	0	11.6	
1,2-dinitrobenzene	95	12.1	
nitrobenzene	5.5 ^b	10.2	1.09 ^c
1,3-dinitrobenzene	115 ^d		0.8 ^c
1,4-dinitrobenzene	39	12.4	0.82 ^c
trinitrotoluene	0	11.6	1.61 ^c
1,2-dicyanobenzene	45	12	
1,4-dicyanobenzene	185; 170 ^d	13	
1,8-dinitronaphthalene	65	13	
trinitrofluorenone	65	13	
tetracyanoquinodimethane	0		14.5 ^e
tetracyanoethylene	0		263 ^e

^a Estimated error in K_a 15%. ^b In CDCl₃/nitrobenzene 1:1 (v/v). ^c At 298 K in CCl₄.^{21a} ^d Determined by a UV titration in CHCl₃, estimated error in K_a 10%. ^e At 298 K in CH₂Cl₂.^{21b}

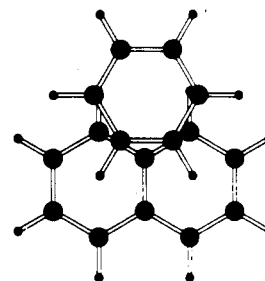
**Figure 5.** Most stable stacked arrangement of the naphthalene–benzene complex.

naphthyl signals shift upfield. Integration of the peaks of the separate conformers in the ¹H NMR spectrum of a solution with known concentrations of **3d** and guest allowed the determination of the association constant K_a of the *aa* conformer with this guest.

In the calculation of the K_a values from the NMR experiments, it is assumed that the guest forms only 1:1 complexes with the *aa* conformer and no complexes with the other conformers. It can easily be shown that an interaction of the guest with the *sa* conformer reduces the apparent K_a with the *aa* conformer. If the guest also has stacking interactions with individual naphthalene moieties, it is to be expected that these interactions have about the same strength in all three conformers. In that case, the calculated K_a is an apparent K_a , representing the excess interaction of the *aa* conformer with the guest due to the formation of a sandwich complex. Specific interactions of the guests with either the *sa* conformation or the *ss* conformation may be detected as a change in the *sa*-to-*ss* ratio in **3d**. As can be seen in Table IV, this ratio is not significantly influenced by any of the guests studied. Apparently, such interactions do not occur. The association constants of two complexes were determined from UV titrations in which a charge-transfer absorption was monitored as a function of the amount of guest added to a solution of **3d** in CHCl₃.

The association constants of **3d** show some remarkable trends when they are compared with those of the model compound hexamethylbenzene (Table IV²¹). For the latter compound—as expected—the K_a values become larger when the guest is a stronger acceptor. Host **3d** displays a completely different behavior. For instance, tetracyanoethylene, which is the best complexant for hexamethylbenzene, is not bound at all by **3d**. On the other hand, 1,3-dinitrobenzene, which forms only a weak complex with hexamethylbenzene, is strongly bound by **3d**. These data corroborate the idea that the complexes between **3d** and the guests of Table IV are electron-donor–electron-acceptor complexes, but do not have a normal geometry. We propose that the guests are sand-

(21) (a) Jurinski, N. B.; DeMaine, P. A. D. *J. Am. Chem. Soc.* **1964**, *86*, 3217. (b) Melby, L. R.; Harder, R. J.; Hertler, W. R.; Mahler, W.; Benson, R. E.; Machel, W. E. *J. Am. Chem. Soc.* **1962**, *84*, 3374.

wiched between the naphthalene walls of **3d** in an offset geometry, as has been calculated for the stacked complex between naphthalene and benzene²² (Figure 5).

When dinitrobenzene is complexed by **3d**, its H-5 proton shifts upfield. This suggests that this guest is bound with its nitro groups pointing away from the cavity of the host. In the complex with trinitrotoluene, the guest cannot attain such a position, since in that case the third nitro group would severely interfere with the glycoluril unit at the base of the cavity. The alternative complex geometry with two nitro groups pointing inward is also disfavored because of electrostatic repulsion between the nitro groups and the carbonyl groups of the host. As a consequence, trinitrotoluene is not bound in the cavity of the aa conformer of **3d**.

On the basis of its acceptor properties, trinitrofluorenone is expected to bind much more strongly in **3d** than are the other guests. Indeed, upon addition this guest to **3d**, a strong color developed. However, this guest did not change the population ratios to the extent expected. Apparently, steric hindrance with the host prevents this guest from taking up a favorable position between the naphthalene moieties of the aa conformer. Consequently, the complex with the aa conformer is not much stronger than that with the sa and ss conformers.

Surprisingly, addition of the equally strong but smaller acceptor tetracyanoethylene (TCNE) to a solution of **3d** caused a color change from colorless to deep blue but no change in the ratio of conformers of **3d**. In the crystal structure of TCNE with naphthalene, the acceptor is lying over the center of one of the benzene rings of naphthalene.²³ In this geometry, there would be a strong steric interference with the glycoluril part of **3d**, thus forcing the guest to take up a less favorable position.

Conclusions and Prospects

The present work has shown that compound **3d** is an efficient receptor for aromatic guests. Binding occurs by an induced-fit mechanism. The host selects the guest on the basis of size rather than on acceptor strength. According to the principle of preorganization, the low abundance of the guest-binding conformer in **3d** is a disadvantage if strong complexation is to be achieved. It would therefore be of interest to synthesize an analog of **3** that is completely in the aa conformer. This can probably be achieved by synthesizing a glycoluril host with more bulky substituents on its convex side.

On the other hand, the occurrence of different conformers can be used to develop molecular switches. In such a switch, the binding of a guest may be controlled by an external factor, e.g., light, or a physical variable, like solvent polarity or redox potential. Work along this line is in progress.

Experimental Section

Compounds. **17b,17c-Dihydro-1,6,10,15-tetrahydroxy-17b,17c-diphenyl-7H,8H,9H,16H,17H,18H-7a,8a,16a,17a-tetraazapentaleno-[1'',6'':5,6,7:3'',4'':5',6',7']dicycloocta[1,2,3-de:1',2',3'-d'e']dinaphthalene-8,17-dione (3b).** A mixture of 2.48 g (5.08 mmol) of **4**, 3.2 g (20 mmol) of 2,7-dihydroxynaphthalene, and 5.5 mL (44 mmol) of SnCl₄ was refluxed for 30 min in 100 mL of 1,2-dichloroethane. After the mixture had been refluxed with aqueous HCl, the product was isolated from the reaction mixture by filtration and washed with MeOH. The product was purified by recrystallization from DMSO to yield 2.1 g (64%) of colorless needles. FAB-MS (*m*-nitrobenzyl alcohol) *m/z*: 663 (M + H)⁺. Anal. Calcd for C₄₀H₃₀N₄O₆·0.5H₂O: C, 71.53; H, 4.65; N, 8.34. Found: C, 71.53; H, 4.63; N, 8.37.

17b,17c-Dihydro-1,6,10,15-tetraacetoxy-17b,17c-diphenyl-7H,8H,9H,16H,17H,18H-7a,8a,16a,17a-tetraazapentaleno-[1'',6'':5,6,7:3'',4'':5',6',7']dicycloocta[1,2,3-de:1',2',3'-d'e']dinaphthalene-8,17-dione (3c). Compound **3b** (0.781 g, 1.18 mmol) was heated at 100 °C in 15 mL of acetic anhydride with 1 mL of pyridine. After 1 h, the solvent was evaporated, and the residue was purified by column chromatography (CHCl₃/MeOH, 97:3 v/v) to yield 0.431 g (44%) of **3b**. ¹H NMR (CDCl₃): see Table I. ¹³C NMR (CDCl₃) (the signals of the sa conformer are given here) δ: 169.72 (acetyl C=O), 158.16 (urea C=O), 149.92, 148.82 (naphthalene C-2,7) 134.55, 134.03,

132.05, 131.92, 131.36, 130.30, 130.08, 128.83, 128.65, 128.18, 126.70, 126.61, 125.53, 122.29, 122.05, 121.71, 121.12 (naphthalene C and Ph C), 84.52, 83.61 (Ph CN), 39.89, 37.08 (naphthalene CH₂N), 21.56, 21.28 (acetyl CH₃). FAB-MS (*m*-nitrobenzyl alcohol) *m/z*: 831 (M + H)⁺. Anal. Calcd for C₄₈H₃₈N₄O₁₀·0.5H₂O: C, 68.65; H, 4.68; N, 6.67. Found: C, 68.56; H, 4.61; N, 6.57.

17b,17c-Dihydro-1,6,10,15-tetramethoxy-17b,17c-diphenyl-7H,8H,9H,16H,17H,18H-7a,8a,16a,17a-tetraazapentaleno-[1'',6'':5,6,7:3'',4'':5',6',7']dicycloocta[1,2,3-de:1',2',3'-d'e']dinaphthalene-8,17-dione (3d). In 25 mL of DMSO, to which 2.5 g of powdered KOH had been added, 1.32 g (1.99 mmol) of **3b** was dissolved. Dimethyl sulfate (1.4 mL, 8.3 mmol) was added, and the mixture was stirred for 1 h at room temperature. The reaction mixture was poured into 250 mL of water. The product was extracted from the aqueous suspension with CH₂Cl₂ and purified by column chromatography (CHCl₃/MeOH, 99.5:0.5 v/v) to yield 1.09 g (76%) of **3d**. ¹H NMR (CDCl₃): see Table I. FAB-MS (*m*-nitrobenzyl alcohol) *m/z*: 719 (M + H)⁺. Anal. Calcd for C₄₄H₃₈N₄O₆·CH₂Cl₂: C, 67.25; H, 5.02; N, 6.97. Found: C, 66.93; H, 4.96; N, 6.94.

The acceptor compounds were commercial products. The dinitro- and dicyanobenzenes, resorcinol, and dinitronaphthalene were purified by recrystallization before use.

2D ¹H NMR Experiments. The EXSY spectra were recorded at 308 K at 500 MHz with the NOESYPH pulse sequence supplied with the Bruker software. TPPI²⁴ was used to obtain quadrature detection in *t*₁; Each of the 512 *t*₁ increments was the accumulation of 16 scans. The relaxation delay was 0.8 s. The mixing time was not randomly varied since the exchanging signals were not *J*-coupled. Before Fourier transformation, the FIDs were multiplied by the $\pi/2.5$ shifted sine-bell function in the F₂ domain, and by the $\pi/2$ shifted sine-bell function in the F₁ domain. The data file was zero-filled, resulting in a spectrum of 1K × 1K real data points, with a resolution of 4.88 Hz/point. A baseline correction was applied to the 2D spectrum. Peak volumes were determined by accumulating the integral in regions of 32 × 24 data points around peaks of interest. In the calculation of rate constants, the average volumes of symmetry-related crosspeaks was used.

Double quantum filtered COSY spectra were recorded at 400 MHz with the COSYPHDQ pulse sequence supplied with the Bruker software; 512 *t*₁ increments were taken. Each FID of 1K data points was the accumulation of 48 scans. A $\pi/2$ shifted squared sine-bell window function was applied in both F₁ and F₂ domains. The data file was zero-filled, resulting in a spectrum of 1K × 1K real data points, with a resolution of 3.88 Hz/point.

Molecular Mechanics Calculations. The MMX force field and the force field developed by Warshel were used without modification. For parameters that were lacking in the MM2P(85) force field, the values were taken from the MMX force field. It was found that the relative energies of the different conformers of **3a** were only marginally influenced by the actual values of the additional parameters.

Determination of Association Constants by ¹H NMR. The association constants of the complexes between the aa conformer of host **3d** and the various guests were determined by integrating the relevant signals of the guest and the different conformers of the host. A CDCl₃ solution 30 mM in **3d** and 55–75 mM in guest was used. The *K*_as (see eq 1) were cal-

$$K_a = \frac{[aa \cdot G]}{[aa] \times [G]} \quad (1)$$

culated from these integrals, assuming that the guest forms only 1:1 complexes with the aa conformer and does not interact with the sa and ss conformers.

In eq 1, [aa·G] is the equilibrium concentration of the complex of the aa conformer with guest G, [aa] is the concentration of uncomplexed aa conformer, and [G] is the concentration of uncomplexed guest. The concentration of uncomplexed aa conformer in the solution containing guest can be determined with the aid of the equilibrium constant *K*_{sa/aa},

$$[aa] = \frac{[sa]}{K_{sa/aa}} \quad (2)$$

which is known from the integration of the spectrum of a solution of **3d** without guest (eq 3).

$$K_{sa/aa} = \frac{[sa]}{[aa]} \quad (3)$$

The assumption is made that [sa] = [sa]_{tot}, i.e., the sa conformer does not complex with G. The other concentrations in eq 1 can be calculated

(22) Jorgensen, W. L.; Severance, D. L. *J. Am. Chem. Soc.* **1990**, *112*, 4768.

(23) Williams, R. M.; Wallwork, S. C. *Acta Crystallogr.* **1967**, *22*, 899.

(24) Marion, D.; Wüthrich, K. *Biochem. Biophys. Res. Commun.* **1983**, *113*, 967.

with the help of eq 2 and the integration of the relevant host and guest signals in the spectrum, which gives the total concentration of G, $([G]_{\text{tot}})$, and the total concentration of the aa conformer of 3c, $([aa]_{\text{tot}})$ (eqs 4 and 5).

$$[aa-G] = [aa]_{\text{tot}} - [aa] \quad (4)$$

$$[G] = [G]_{\text{tot}} - [aa-G] \quad (5)$$

Determination of Association Constants by UV Titrations. Stock solutions were prepared in CHCl_3 , containing approximately 2 mM 3d (stock solution A). From these stock solutions, new solutions containing also approximately 1 M guest were prepared (stock solution B). Stock solution A (1.7 mL) was placed in a 1-cm cuvette. For each successive data point, a 25- μL aliquot of stock solution B was added to the cuvette.

K_a s were calculated with the help of a computer program that evaluates K_a and ϵ in a way analogous to that described for the determination of the association constants from the ^1H NMR shift titrations.²⁵ Excellent fits were obtained assuming an experimental error of 0.0003 absorption units. The extinction coefficients of the free guests and 3d, which are required for the calculations, were determined separately. The K_a values for binding to the aa conformer were obtained by dividing the calculated K_a values by the fraction of molecules 3d that are in the aa conformation when no guest is present (0.027). This procedure is allowed if it is assumed that only the aa conformer of 3d binds guest molecules (see text).

(25) de Boer, J. A. A.; Reinhoudt, D. N.; Harkema, S.; van Hummel, G. J.; de Jong, F. *J. Am. Chem. Soc.* 1982, 104, 4073.

Gas Chromatographic Study of Solute Hydrogen Bond Basicity

Jianjun Li, Yunke Zhang, Hsiu Ouyang, and Peter W. Carr*

Contribution from the Department of Chemistry, University of Minnesota, 207 Pleasant Street, Minneapolis, Minnesota 55455. Received May 29, 1992

Abstract: The purpose of the present work was to develop a scale of relative hydrogen bond basicity for a wide variety of solutes by means of their retention in gas chromatography. We used a powerful hydrogen bond donor (4-dodecyl- α,α -bis-(trifluoromethyl)benzyl alcohol) as an active hydrogen bond donor phase and a related ether (4-dodecyl- α,α -bis(trifluoromethyl)benzyl methyl ether) as a chemically similar but hydrogen bond inert reference stationary phase. The results are compared to a free energy based scale for the formation of 1:1 hydrogen bond complexes. In general, agreement is good, but a number of systematic discrepancies are found. FT-IR studies show that complexes with stoichiometries higher than 1:1 can be formed even for species as simple as THF in the presence of excess donor. Our results indicate that the use of hydrogen bond basicity scales based on the free energy of formation of hydrogen bond complexes to the rationalization of solvation-related phenomena must be used with discretion, at least in solvents which are very strong hydrogen bond acids.

Introduction

The phenomenon of hydrogen bonding is an immensely important topic in chemistry and biology.¹ The structure of bulk water² and the specific chemical and physical properties³ of water are related to hydrogen bonding. The hydrophobic effect⁴ and phenomena such as the self-assembly of micelles^{4b-d} and vesicles^{4c,d} and the folding of proteins^{4e} are all partly a consequence of specific hydrogen bonding interactions in water. In addition, water is a strong hydrogen bond donor (acid). In fact, it is a better acid than it is a base.⁵ Kamlet, Taft, and their collaborators have shown that solutes which are strong hydrogen bond bases are more soluble in water,⁶ partition better from octanol into water,⁷ and are less retained in reversed-phase liquid chromatography⁸ than are otherwise similar but less basic solutes. Such important properties of a molecule as its toxicity to various organisms⁹ and its partitioning between blood and various body tissues¹⁰ correlate strongly with the species' ability to accept a hydrogen bond. For these reasons, we feel that empirical scales of solute hydrogen bond basicity are very significant.

Hydrogen bond complexation represents a specific type of donor-acceptor¹¹ interaction. There have been many efforts to establish scales of relative acidity and basicity.¹² One of the best known approaches is the dual parameter scale of Drago and Wayland.^{12a} Maria and Gal¹³ have analyzed a very wide variety of basicity-dependent properties (BDPs). Using principle components analysis, they have shown that virtually all BDPs can be described as the weighted sum of two uncorrelated abstract factors. These abstract factors are describable as being primarily electrostatic and covalent, in agreement with the concepts of Drago.^{12a}

Abraham has shown that hydrogen bond formation generally corresponds to a specific combination of these abstract factors

(1) (a) Pimentel, G. C.; McClellan, A. L. *Hydrogen Bond*; W. H. Freeman: San Francisco, 1960. (b) Vinogradov, S. N.; Linnell, R. H. *Hydrogen Bonding*; Van Nostrand Reinhold: New York, 1971. (c) Jeffrey, G. A.; Saenger, W. *Hydrogen Bonding in Biological Structures*; Springer-Verlag: New York, 1991.

(2) (a) Symons, M. C. R. *Chem. Br.* 1989, 25, 491, 5. (b) Frank, H. S. *Fed. Proc. Suppl.* 1965, 15, S-1-S-11. (c) Frank, H. S.; Wen, W.-Y. *Discuss. Faraday Soc.* 1957, 24, 133.

(3) Franks, F. *Water*; The Royal Society of Chemistry: London, 1983.

(4) (a) Ben-Naim, A. *Hydrophobic Interactions*; Plenum: New York, 1980. (b) Tanford, C. *The Hydrophobic Effect: Formation of Micelles and Biological Membranes*; Wiley-Interscience: New York, 1980. (c) Degiorgio, V.; Corti, M. *Physics of Amphiphiles—Micelles, Vesicles, and Microemulsions*; North-Holland Pub. Co.: New York, 1983. (d) Fendler, J. H. *Membrane Mimetic Chemistry: Characterizations and Applications of Micelles, Microemulsions, Monolayers, Bilayers, Vesicles, Host-Guest Systems, and Polyions*; Wiley: New York, 1982. (e) Creighton, T. E. *Proteins: Structure and Molecular Properties*; W. H. Freeman Co.: New York, 1984.

(5) Marcus, Y. *J. Solution Chem.* 1991, 20, 929.

(6) (a) Taft, R. W.; Abraham, M. H.; Doherty, R. M.; Kamlet, M. J. *Nature (London)* 1985, 313, 384. (b) Kamlet, M. J.; Doherty, R. M.; Abraham, M. H.; Carr, P. W.; Doherty, R. F.; Taft, R. W. *J. Phys. Chem.* 1987, 91, 1996.

(7) (a) Kamlet, M. J.; Abraham, M. H.; Doherty, R. M.; Taft, R. W. *J. Am. Chem. Soc.* 1984, 106, 464. (b) Kamlet, M. J.; Doherty, R. M.; Abraham, M. H.; Marcus, Y.; Taft, R. W. *J. Phys. Chem.* 1988, 92, 5244. (c) Kamlet, M. J.; Abraham, M. H.; Carr, P. W.; Doherty, R. M.; Taft, R. W. *J. Chem. Soc., Perkin Trans. II* 1988, 2087.

(8) (a) Sadek, P. C.; Carr, P. W.; Doherty, R. M.; Kamlet, M. J.; Taft, R. W.; Abraham, M. H. *Anal. Chem.* 1985, 57, 2971. (b) Carr, P. W.; Doherty, R. M.; Kamlet, M. J.; Taft, R. W.; Melander, W.; Horvath, C. *Anal. Chem.* 1986, 58, 2674. (c) Leahy, D. E.; Carr, P. W.; Pearlman, R. S.; Taft, R. W.; Kamlet, M. J. *Chromatographia* 1986, 21, 473. (d) Park, J. H.; Carr, P. W.; Abraham, M. H.; Taft, R. W.; Doherty, R. M.; Kamlet, M. J. *Chromatographia* 1988, 25, 373.

* To whom correspondence should be addressed.